

Intelligent Compact Floor Scrubber Dryer - Artist 1

Model	Artist 1
Power Supply	24V/13Ah battery (x2), removable, supports single battery use
Color	Grey
Runtime	75 mins / battery
Charging Time	1h 40mins / battery
Noise Level	60 dB(A)
Protection Index	IPX4
HEPA Filtration	H10
Electrolyzed Water Module	99.99% sterilization, reduces cleaning agent use (PRO version only)
Cleaning Agent	Works with low-foam agents, pH 6-8
Operating Modes	Eco/Turbo/Brush-only Auto/Sterilization (PRO Version only)
Work Capacities	
Cleaning Efficiency	800-1200m ² /h
Solution Tank Capacity	4L
Recovery Tank Capacity	4L
Working Width	40 cm
Brushing Characteristics	
Brush Speed	350 rpm
Brush Pressure	15 kg
Theoretical Suction Power	20,000 Pa
Actual Suction Power	8,000 Pa
Motor	
Brush Motor Power	250 W
Suction Motor Power	150 W
Weight and Dimensions	
Net Weight (Machine only)	49.5 lbs (22 kg)
Gross Weight (Machine & standard package)	SE Version:67.2 lbs (30.5 kg) PRO Version:74.1 lbs (33.6 kg)
Machine Dimensions	46.1" x 18.5" x 17.1" (1170 mm x 469 mm x 435 mm)
Package Dimensions	46.9" x 20.7" x 15.7" (1190 mm x 525 mm x 400 mm)
Smart Interaction	
Digital Platform	Manage and monitor devices, and collect cleaning data via the app.
Screen	High-definition 4.1-inch LCD.
Voice Speaker	Supports multiple languages.
Dirt Detection	Adjusts cleaning intensity based on dirt levels. (PRO Version only)
Device Status Detection	Monitors for empty or full tanks, blockages, and battery issues.
WIFI	Yes
4G	Yes (PRO version only)

Intelligent Compact Floor Scrubber Dryer - **Artist 1**

Product Size



Artist 1



Package Size

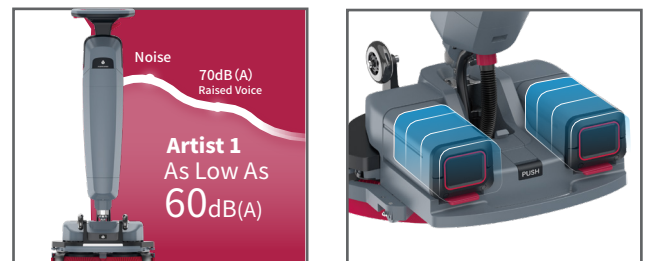
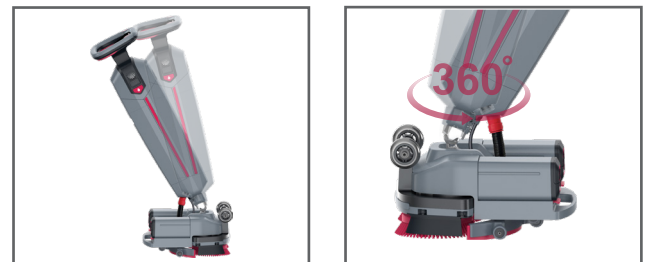
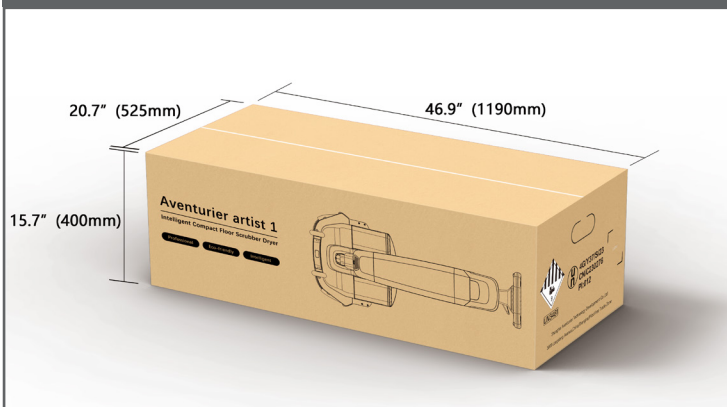

What's in the box

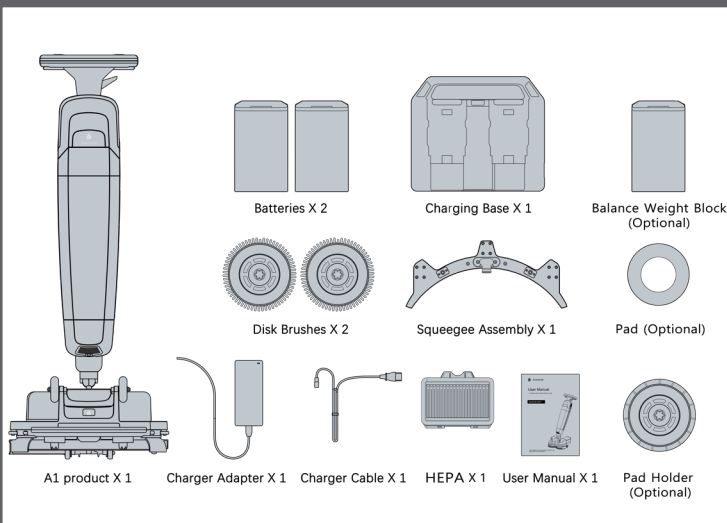

Key Features

Two Support Angles

Easier cleaning and short breaks without leaning the machine.

360-Degree Flexibility

Adjusts to 360 degrees for versatile cleaning.

Quiet Operation

Runs below 60dB(A) for a quiet environment.

Dual Battery System

One battery in use, the other charging.

Suitable Floor Types



Note : Data is based on Eco Mode. Battery life varies with usage.